

# PRODUCT SPECIFICATION

<b>Part No.:</b>	<b>AC-XP-Q1G10-20</b>	
<b>Description:</b>	10G SFP+ Transceiver, CWDM 1270-1610 20km	
<b>Release Date</b>	<b>Rev.</b>	<b>Revision Change Description</b>
2017/06/07	A0	New Release
2020/12/28	A1	Template Update

## Features

---

- ✧ Up to 10.3125Gbps Data Links
- ✧ CWDM DFB transmitter and PIN receiver
- ✧ Metal enclosure, for lower EMI
- ✧ Single +3.3V power supply
- ✧ Hot-pluggable
- ✧ Power dissipation < 1.5W
- ✧ Operating temperature range:  
Commercial: 0°C~+70°C  
Industrial: -40°C~+85°C
- ✧ RoHS compliant
- ✧ 2-wire interface with integrated Digital Diagnostic monitoring
- ✧ Up to 20km transmission over SMF

## Application

---

- ✧ 10GBASE-ER/EW
- ✧ 10G Ethernet

## Standard

---

- ✧ SFF-8431(SFP+ MSA )
- ✧ SFF-8472
- ✧ IEEE 802.3ae

## Wavelength selection

Wavelength	xx	Clasp Color Code	Wavelength	xx	Clasp Color Code
1270 nm	27	Gray	1370 nm	37	Green
1290 nm	29	Gray	1390 nm	39	Yellow
1310 nm	31	Gray	1410 nm	41	Orange
1330 nm	33	Purple	1430 nm	43	Red
1350 nm	35	Blue	1450 nm	45	Brown
1470 nm	47	Gray	1550 nm	55	Yellow
1490 nm	49	Purple	1570 nm	57	Orange
1510 nm	51	Blue	1590 nm	59	Red
1530 nm	53	Green	1610 nm	61	Brown

## Specification

Absolute Maximum Ratings				
Parameter	Symbol	Min	Max	Unit
Storage temperature	TS	-40	85	°C
Power Supply Voltage	Vcc3	-0.3	+4	V
Relative Humidity	RH	5	95	%
Signal Input Voltage		Vcc-0.3	Vcc+0.3	V

Recommended Operating Conditions					
Parameter	Symbol	Min	Typical	Max	Unit
Operating Case Temperature (Commercial)	Tc	0		70	°C
Operating Case Temperature (Industrial)	Tc	-40		85	°C
Power Supply Voltage	Vcc3	3.13	3.3	3.47	V
Supply Current	Icc3			450	mA
Data Rate			10.3125	11.3	Gbps
Fiber Length 9/125μm core SMF		-	20	-	km

Electrical Characteristics						
Parameter	Symbol	Min	Typical	Max	Unit	Notes
Transmitter differential input voltage	Vin,pp	180		1200	m V	
Receiver differential output Voltage	Vout,pp	300		850	m V	
Input differential impedance	Rin		100		Ω	1
LOS Fault	VLOS fault	Vcc-1.3		VCCHost	V	2

LOS Normal	VLOS norm	Vee		Vee+0.8	V	2
Transmit disable voltage	VIH	Vcc-1.3		Vcc	v	
Transmit enable voltage	VIL	Vee		Vee+0.8	v	
Data output rise time	Tr	30			ps	
Data output fall time	Tf	30			ps	
Transmit Disable Assert Time				10	us	
Power Supply Rejection	PSR			100	mVpp	3

**Notes:**

- 1) Connected directly to TX data input pins. AC coupled thereafter.
- 2) Loss Of Signal is LVTTL. Logic 0 indicates normal operation; logic 1 indicates no signal detected.
- 3) Receiver sensitivity is compliant with power supply sinusoidal modulation of 20 Hz to 1.5 MHz up to specified value applied through the recommended power supply filtering network.

Optical transmitter Characteristics						
Parameter	Symbol	Min	Typical	Max	Unit	Notes
Launched Power (avg.)	Pout	-3		2	dBm	4
Operating Wavelength Range	$\lambda_c$	$\lambda-6.5$		$\lambda+6.5$	nm	5
Spectral Width(-20dB)	$\Delta\lambda$			1	nm	
Side Mode Suppression Ratio	SMSR	30			dB	
Extinction Ratio	ER	3.5			dB	
Transmitter and Dispersion Penalty	TDP			3.2	dB	
Output Eye Diagram	Compliant with ITU-T G.691 eye mask and IEEE802.3ae eye mask					
Optical receiver Characteristics						
Parameter	Symbol	Min	Typical	Max	Unit	Notes
Receiver Sensitivity	S			-14.4	dBm	6
Wavelength Range	$\lambda_c$	1270		1610	nm	
Optical Power Input Overload	P <sub>in-max</sub>	0.5			dBm	
LOS	Optical De-assert	Pd		-15	dBm	
	Optical Assert	Pa	-30			
LOS hysteresis		0.5			dB	

**Notes:**

- 4) Class 1 Laser Safety per FDA/CDRH and IEC-825-1 regulations.
- 5) "λ" refer to wavelength selection.
- 6) Receiver Reflectance Measured with a PRBS 2<sup>31</sup>-1 test pattern, @10.3125Gbps, ER=3.5dB, BER<10<sup>-12</sup>.

## Pin Descriptions

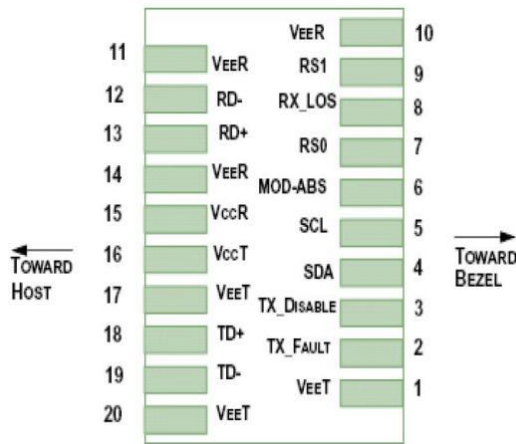

Figure 1 SFP+ Pad assignment Top View

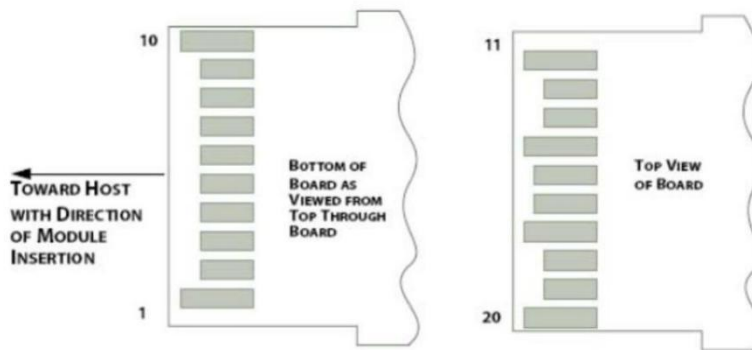

Figure 2 SFP+ Module Contact Assignments

## Pin Assignment

Pin	Symbol	Description	Notes
1	VeeT	Module Ground(Common with Receiver Ground)	1
2	TX_Fault	Transmitter Fault, Low: normal; High: abnormal	2
3	TX_Disable	Transmitter Disable High: Transmitter off Low: Transmitter on	3
4	SDA	2-Wire Serial Interface Data Line (Same as MOD-DEF2 in INF-8074i)	4
5	SCL	2-Wire Serial Interface Data Line (Same as MOD-DEF2 in INF-8074i)	4
6	Mod_ABS	Module Absent, Connect to VeeT or VeeR in Module	4

7	RS0	Rate Select 0, optionally controls SFP+ module receiver	5
8	RX_LOS	Receiver Loss of Signal indication High: loss of signal Low: signal detected	6
9	RS1	No connection required	1
10	VeeR	Receiver Ground	1
11	VeeR	Receiver Ground	1
12	RD-	Receiver Inverted DATA out. AC Coupled. CML-O	
13	RD+	Receiver Non-inverted DATA out. AC Coupled. CML-O	
14	VeeR	Receiver Ground	1
15	VccR	Receiver Power Supply	
16	VccT	Transmitter Power Supply	
17	VeeT	Transmitter Ground	1
18	TD+	Transmitter Non-Inverted DATA in. AC Coupled. CML-I	
19	TD-	Transmitter Inverted DATA in. AC Coupled. CML-I	
20	SDA	Transmitter Ground	1

**Notes:**

- 1) Circuit ground is internally isolated from chassis ground.
- 2) TFAULT is an open collector/drain output, which should be pulled up with a 4.7k – 10k Ohms resistor on the host board if intended for use. Pull up voltage should be between 2.0V to Vcc + 0.3V. A high output indicates a transmitter fault caused by either the TX bias current or the TX output power exceeding the preset alarm thresholds. A low output indicates normal operation. In the low state, the output is pulled to <0.8V.
- 3) Laser output disabled on TDIS >2.0V or open, enabled on TDIS <0.8V.
- 4) Should be pulled up with 4.7kΩ- 10kΩ host board to a voltage between 2.0V and 3.6V. MOD\_ABS pulls line low to indicate module is plugged in.
- 5) Internally pulled down per SFF-8431 Rev 4.1.
- 6) LOS is open collector output. It should be pulled up with 4.7kΩ – 10kΩ on host board to a voltage between 2.0V and 3.6V. Logic 0 indicates normal operation; logic 1 indicates loss of signal.

## Block Diagram

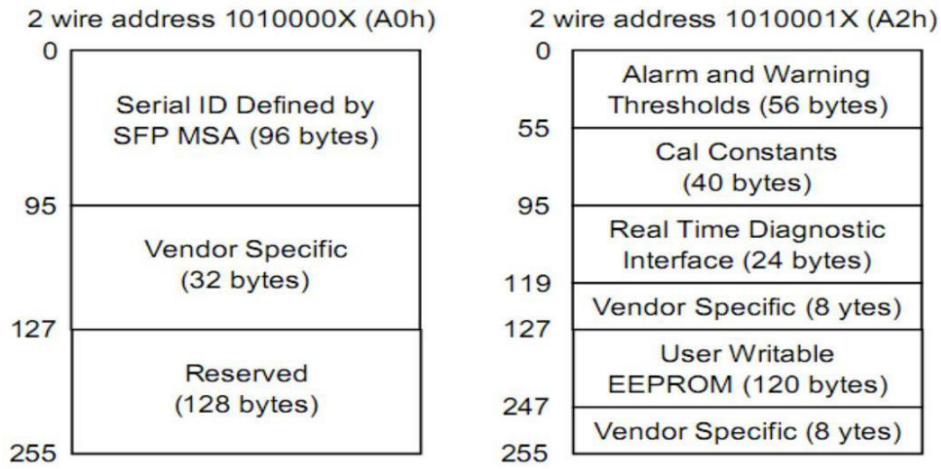

## Digital Diagnostic Memory Map

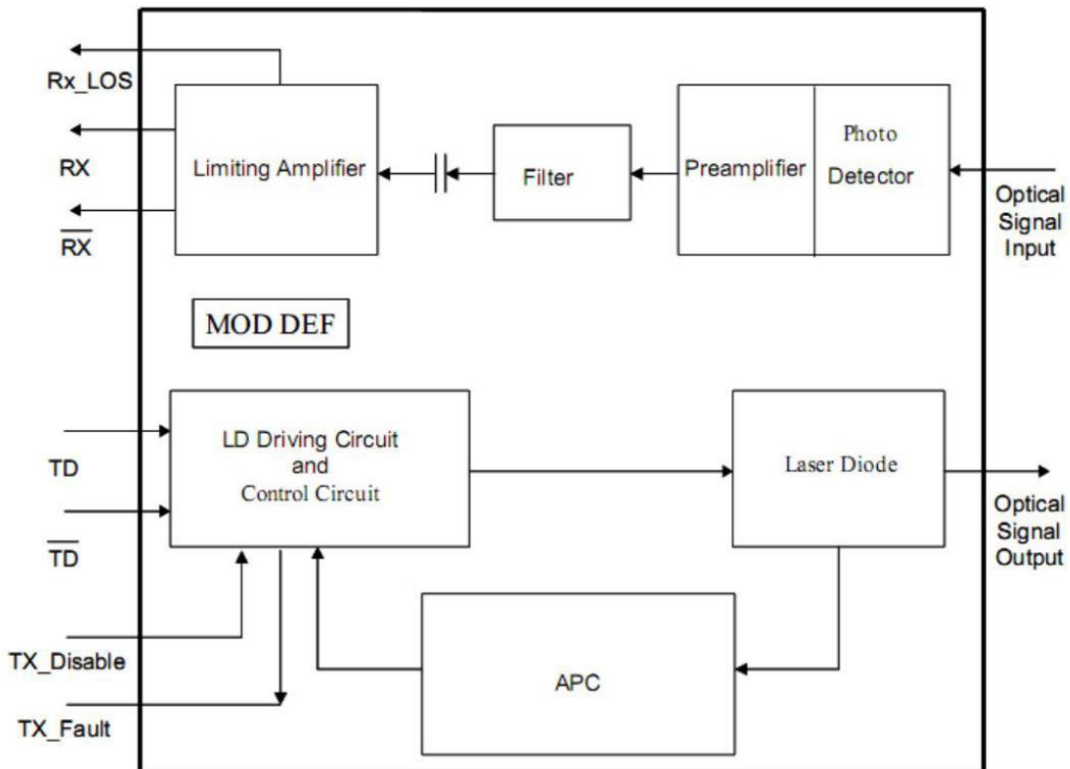

## Package Outline

Dimensions are in millimeters. All dimensions are  $\pm 0.2\text{mm}$  unless otherwise specified. (Unit: mm)

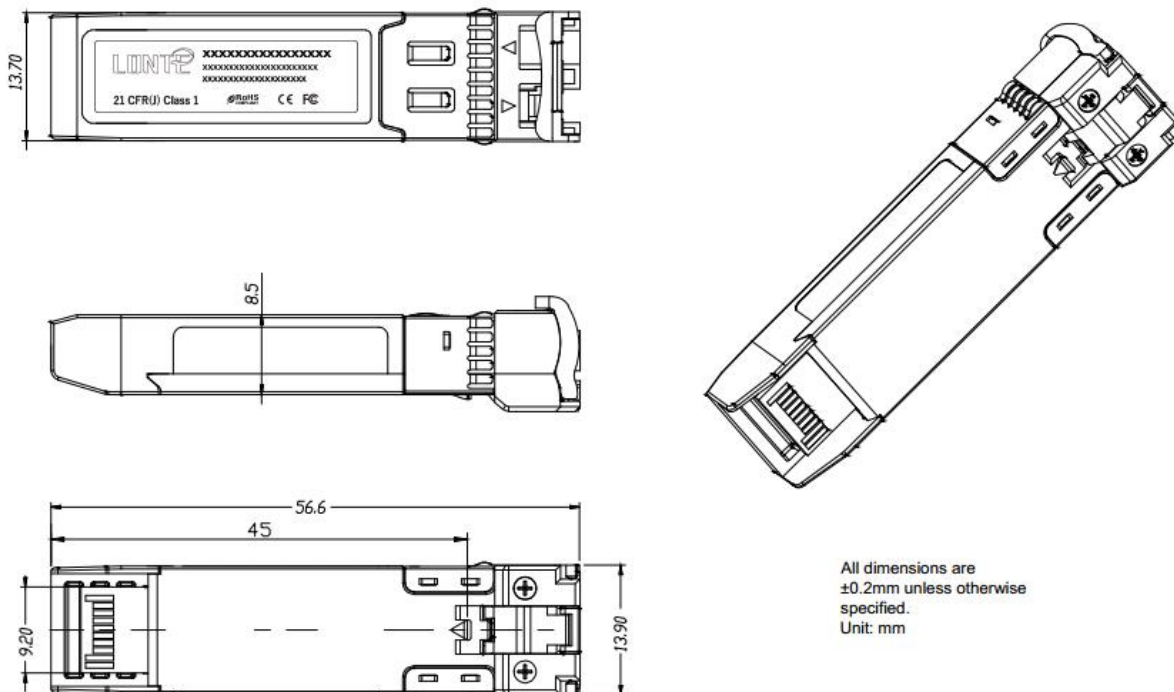

## Regulatory Compliance

Feature	Test	Method
Electrostatic Discharge (ESD) to the Electrical Pins	MIL-STD-883E Method 3015.7	Class 1(>1000V for SFI pins, >2000V for other pins.)
Electrostatic Discharge (ESD) Immunity	IEC61000-4-2	Class 2(>4.0kV)
Electromagnetic Interference (EMI)	CISPR22 ITE Class B FCC Class B CENELEC EN55022 VCCI Class 1	Comply with standard
Immunity	IEC61000-4-3	Comply with standard
Eye Safety	FDA 21CFR 1040.10 and 1040.11 EN (IEC) 60825-1,2	Compatible with Class I laser Product

## Ordering Information

Part. No	Specifications								
	Pack	Rate (Gbps)	Tx (nm)	Po (dBm)	RX	Sen (dBm)	Temp (°C)	Reach (km)	DDM
AC-XP-Q1G10-20	SFP+	10.3125	CWDM DFB	-3~2	PIN	<-14.4	0~70	20	Y
AC-XP-Q1G10-20F	SFP+	10.3125	CWDM DFB	-3~2	PIN	<-14.4	-40~85	20	Y